



# SWING DOOR ACCESS GATE



KABEX®

## DESCRIPTION

KABEX Swing Door Access Gate are used for automatic human access in OFFICE BUILDING with CARD ACCESS SYSTEM. Slim design cater for more lanes in office lifts lobby and tight places.

They are also installed in areas such as:

- Factories
- Airports
- Stadiums
- Railway Platforms
- Passenger Terminals.

## FEATURES

- TCP/IP communication
- Programmable operation mode

## SPECIFICATIONS

Drive System	Incorporate a DC motor with servo positioning drive to open and close the door. Motor is cut off during inactive state saving power consumption and prevent overheating. Locking clutch will protect the drive system in the event of force entry.
Safety	Photo Electric Beams
Material	SS304 and Tempered Glass (housing - 1.5mm thickness)
Input Voltage	230V, 50Hz
Rated Current	Typical : 0.5A, Inrush : 2.0A
Lane Width (mm)	600 (max 900)
Flow Rate	15 - 30 person/min
Interface I/O	Open/Close/Manual open/Fire Alarm/Gate status Accept open enable for gate as single or bi-direction
Noise (dB)	≤50
Dimension (H x L x W)	1000 x 1400 x 140

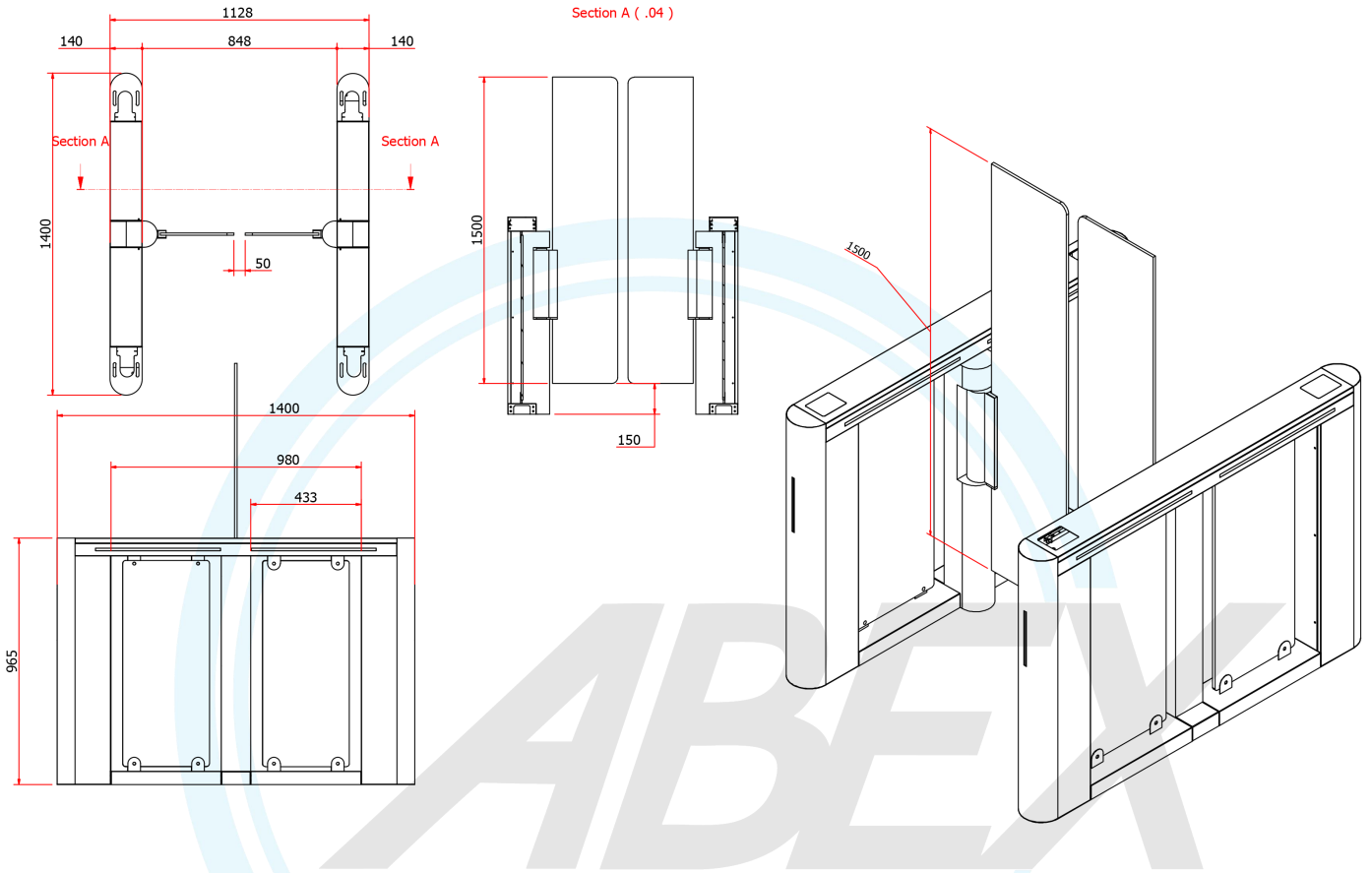

ORDERING INFORMATION

EXAMPLE : SD-140030411

