

# PXI RF Relay Modules

[PXI-2542](#), [PXIe-2542](#), [PXI-2548](#), [PXI-2549](#), [PXI-2558](#), [PXI-2559](#), [PXI-2599](#), and [PXI-2799](#)



- **Software:** Includes interactive soft front panel, API support for LabVIEW and text-based languages, shipping examples, and detailed help files
- Electromechanical and FET relay options
- Bandwidth up to 40 GHz
- Underminated and terminated options
- Onboard relay count tracking
- Ability to store RF path calibration information in NI Switch Executive

## Built for Automated Test and Measurement

PXI RF Relay Modules offer single-pole double-throw (SPDT) and terminated switches. SPDT models include excellent insertion loss, voltage standing-wave ratio (VSWR), and isolation parameters to minimize signal degradation. You can use the onboard relay-count-tracking feature on these models to predict relay lifetime and reduce unexpected system downtime. SPDT models are also well-suited for passing high-order harmonics from PXI RF Signal Upconverter Modules or routing multiple sources to PXI RF Signal Downconverter Modules. Terminated switch models feature front-mounted SMA connectors and high-performance solid-state relays for fast switching time and unlimited mechanical lifetime. These models also include termination on every COM line and channel, which helps minimize reflections of the RF signal and protect your instruments.

Additionally, NI switch modules offer advanced features, such as hardware triggering, onboard relay count tracking, and a wide variety of reconfigurable models, providing you the option to modify the topology of the switch based on your needs. These advanced features offer a smarter way to tackle difficult applications in industries ranging from consumer electronics to aerospace and defense.

Table 6. NI offers a variety of PXI RF Relay Modules, varying in relay configuration, channel density, relay type, and bandwidth, allowing you to pick the model that best fits your needs.

	Number of Relays	Relay Configuration	Maximum Bandwidth	Characteristic Impedance	Termination	Relay Type
PXI-2542 and PXIe-2542	4	SPDT	6.6 GHz	50 $\Omega$	Yes	FET
PXI-2548	4	SPDT, latching	2.7 GHz	50 $\Omega$	No	EMR
PXI-2549	2	SPDT, latching	2.7 GHz	50 $\Omega$	Yes	EMR
PXI-2558	4	SPDT, latching	2.5 GHz	75 $\Omega$	No	EMR
PXI-2559	2	SPDT, latching	2.5 GHz	75 $\Omega$	Yes	EMR
PXI-2599	2	SPDT, latching	26.5 GHz	50 $\Omega$	No	EMR
PXI-2799	2	SPDT, latching	40 GHz	50 $\Omega$	No	EMR

## Detailed View of PXIe-2542 RF Relay Module

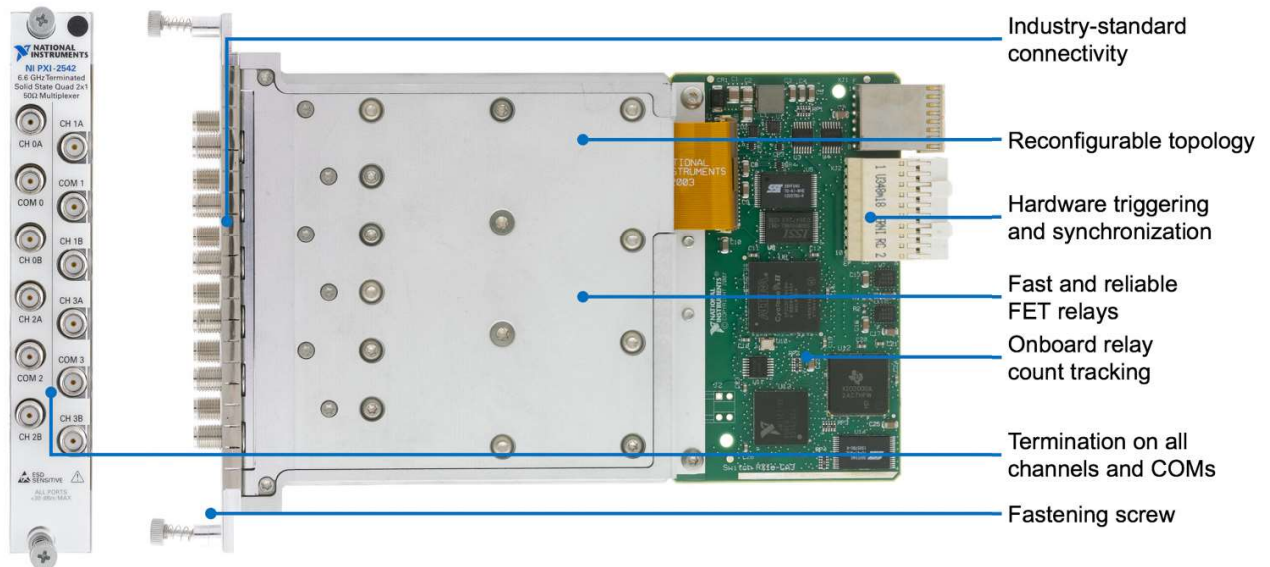

## Key Features

### Synchronization and Integration

NI switches use the inherent timing and synchronization capabilities of the PXI chassis<sup>1</sup>. You can store a list of switch connections in memory onboard the switch module and then use the integrated hardware scanning and triggering engine to advance the switch sequence and rapidly communicate with any PXI instrument that can send and receive digital triggers, such as DMM or oscilloscope. This advanced switching method removes the software overhead and reduces the bus latency associated with traditional software-controlled switching operations for faster test execution with more repeatable timing.

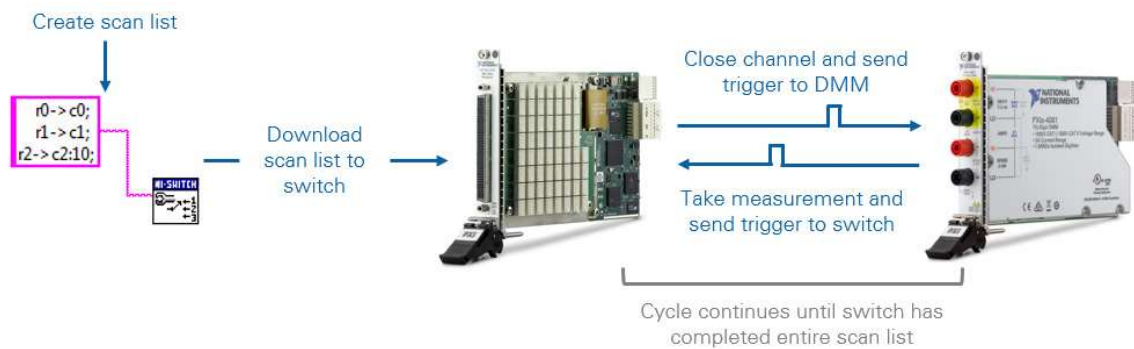

<sup>1</sup>Triggering is available on most NI switches. To check if this feature is supported by a switch module, reference the “Trigger Characteristics” section of the product specification document.

## NI-SWITCH Soft Front Panel

The NI-SWITCH driver software includes an interactive soft front panel for full out-of-the-box functionality. This interactive soft front panel allows you to configure the switch topology and change switch connections with a simple click. In addition, you can use the **Debug Driver Session** mode to monitor and debug the switch during automated measurement. For example, you can monitor which signal paths are active, which individual relays are open/closed, and how many times each relay has been used.

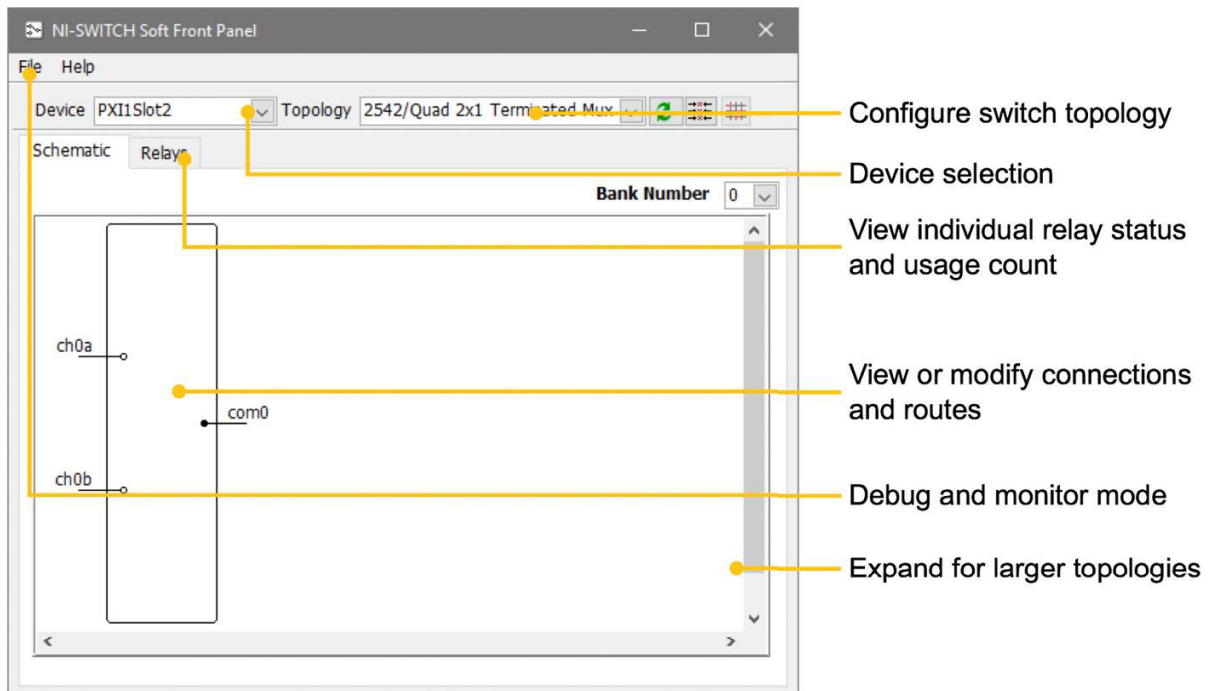

## NI-SWITCH Application Programming Interface (API)

In addition to the soft front panel, the NI-SWITCH driver includes a best-in-class API that works with a variety of development options such as LabVIEW, C, C#, and others. The driver also provides access to help files, documentation, and dozens of ready-to-run shipping examples you can use as a starting point for your application.

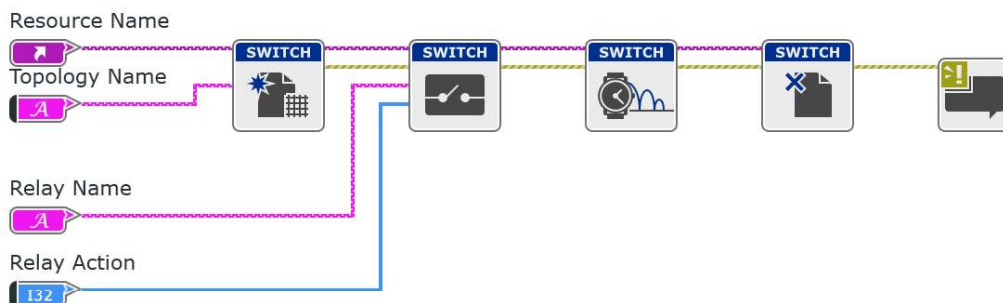

## Switch Executive Application Software

While the NI-SWITCH driver provides all the low-level functionality required to program switch actions, [Switch Executive](#) is application software for intelligent switch management and routing that accelerates development and simplifies maintenance of complex switch systems. The point-and-click graphical configuration and automatic routing capabilities make it easy to design your switch system. Using intuitive channel aliases and route names keeps your system documented for future modifications. Save time and increase test code reuse by integrating your system with TestStand, LabVIEW, LabWindows™ /CVI, and Measurement Studio.

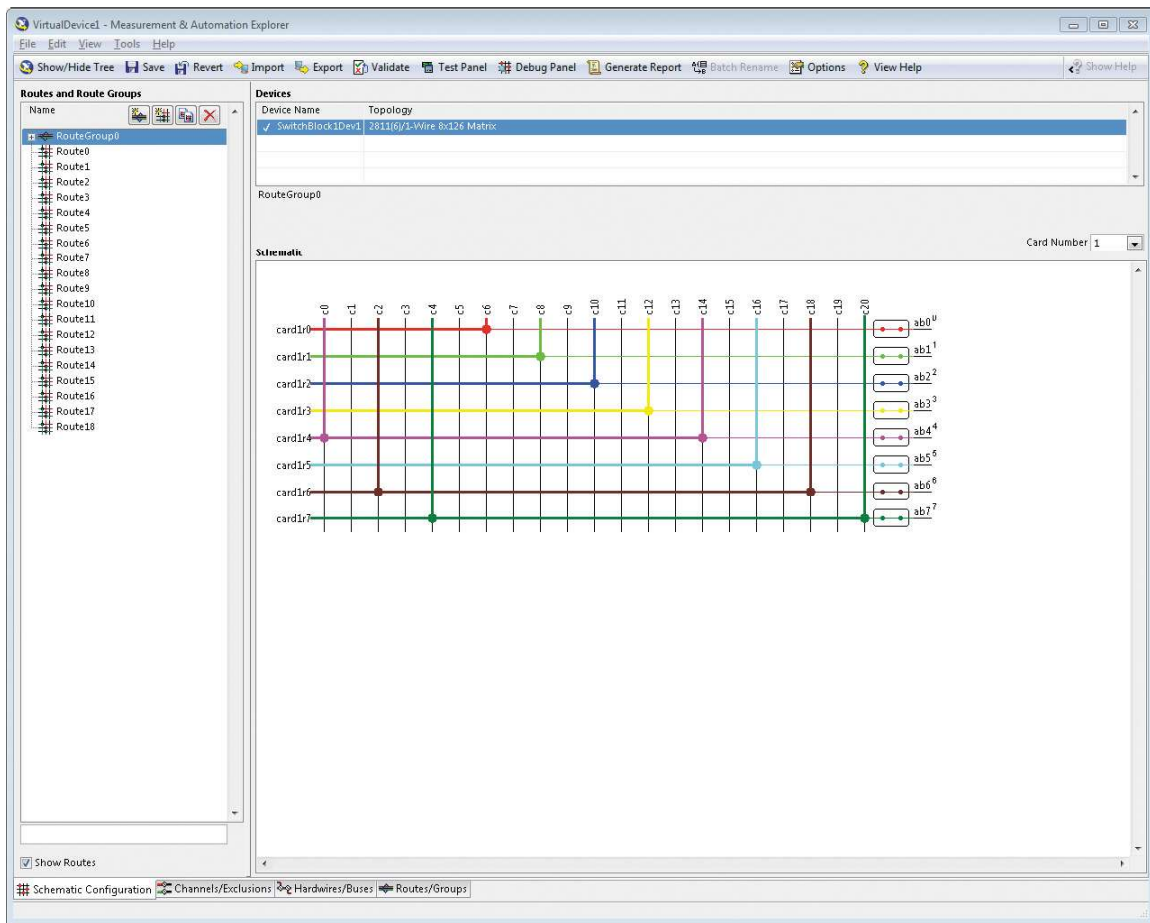

- Graphically configure routes and route groups
- Develop reusable switching code and integrate it into NI TestStand or NI LabVIEW
- Automatically route signals between switch endpoints
- Scale switch configuration using Microsoft Excel
- Maintain switch configuration using route validation, reporting and debugging features